

Conceptual processing effects on automatic memory

DAWN M. McBRIDE and HEATHER SHOUEL
Illinois State University, Normal, Illinois

In the present study, influences of conceptual processing on automatic forms of memory were investigated, using a category production task. The experiment employed Jacoby's (1991) process dissociation procedure and fits of multinomial models to estimate conscious and automatic memory for semantic and graphemic study tasks. Memory estimates from a generate-source model indicated more automatic memory for semantic than for graphemic items on the category production task. These results provide support for conceptual processing influences on automatic forms of memory.

In numerous recent studies, researchers have examined the relation between implicit and explicit forms of memory (see Roediger & McDermott, 1993, for a review). Explicit memory is defined by retrieval that is voluntary, such as retrieval that occurs on recall or recognition tests. Subjects are instructed to remember a specific event (such as a study episode) to complete the task. Implicit memory involves involuntary or automatic retrieval. Word stem completion, word fragment completion, and category exemplar production are examples of some of the implicit tasks that have been studied. In these tasks, subjects are instructed to complete the task with the first word they can think of, with no reference being made to the study episode.

When task performance is compared, some implicit and explicit memory tasks have been dissociated, whereas other explicit and implicit tasks have produced similar results. For example, when implicit word stem completion performance is compared with explicit cued stem recall, levels-of-processing study manipulations affect the explicit task performance but typically show no effect on the implicit task (Roediger, Weldon, Stadler, & Riegler, 1992). However, some studies have indicated that a small but reliable levels-of-processing effect can be found on implicit tasks (Brown & Mitchell, 1994; Challis & Brodbeck, 1992; Horton, Wilson, & Evans, 2001). In addition, when a conceptual task, such as category exemplar production, is considered (i.e., semantic retrieval cues are given), the level of processing does appear to affect implicit task performance (Hamann, 1990; Lee, 2000; Sriniwas & Roediger, 1990; Weldon & Coyote, 1996). Similar results were found when attention was divided at study. Dividing attention reduces explicit memory performance on a word fragment task but does not affect implicit per-

formance (Mulligan, 1998). On the other hand, divided attention was found to reduce implicit and explicit memory when measured with a category production task (Mulligan, 1997). However, the conclusion that conceptual processing influences conceptual implicit tasks, such as the category production task, relies on the assumption that implicit tasks reflect only implicit memory. These results might, instead, reflect explicit contamination (i.e., use of an intentional retrieval strategy) in the implicit task.

Process Dissociation Procedure

As Jacoby, Toth, and Yonelinas (1993) pointed out, a problem with relying on task performance to learn about explicit and implicit memory is that the tasks may not be *process pure*. In other words, subjects may engage in conscious (intentional) retrieval in an implicit task and use automatic (unintentional and lacking in awareness that items were studied) memory to complete explicit memory tasks. When this occurs, the task performance is contaminated by a mixture of processes and does not allow a *pure* measurement of implicit and explicit forms of memory. Therefore, Jacoby et al. recommended use of Jacoby's (1991) process dissociation procedure (PDP) to estimate *uncontaminated* conscious (*C*) and automatic (*A*) memory processes. The PDP involves use of two retrieval tasks, one task in which conscious and automatic memory both contribute to target (study item) responses (inclusion task) and one task in which the processes work in opposition (exclusion task).

In fact, in lieu of task performance comparisons, the PDP has now been used in many studies to dissociate conscious and automatic memory processes. Toth, Reingold, and Jacoby (1994), for example, found that for a stem completion task, PDP estimates of conscious memory were affected by the level of processing at study, whereas automatic memory estimates were similar across study tasks, thus confirming the typical dissociation previously shown in task performance results. Toth et al. concluded that automatic memory measured in a stem completion task was not affected by conceptual processing, whereas

The authors thank Glen Bodner, Jeffrey Toth, and Daryl Wilson for helpful comments and suggestions on an earlier version of this article. Correspondence concerning this article should be addressed to D. M. McBride, Illinois State University, Department of Psychology, Campus Box 4620, Normal, IL 61790-4620 (e-mail: dmmcbri@ilstu.edu).

conscious memory was affected. Because of the perceptual nature of the test cues (three-letter word stems), stem completion has been proposed to rely primarily on perceptual processing, which may account for Toth et al.'s results. However, these results do not preclude possible conceptual processing effects on automatic memory for other tasks. Toth and Reingold (1996) suggested that conceptual processing may influence automatic memory in conceptual tasks. They presented evidence of conceptual effects on automatic forms of memory but also pointed out that most of the evidence comes from studies in which task performance measures were used, and few of the results have been confirmed with the PDP.

Unlike word stem completion, tasks that use conceptual retrieval cues, such as category exemplar production, may rely primarily on conceptual processing. For example, Weldon and Coyote (1996) found levels-of-processing effects for an implicit form of the category production task. However, because their study involved a comparison of implicit and explicit task performance, possible conscious retrieval contamination cannot be ruled out in the implicit task. As was stated by Toth and Reingold (1996), the PDP has rarely been applied to such tasks; therefore, it is not known whether conceptual processing truly influences automatic memory for conceptual tasks. One exception is a study conducted by Schmitter-Edgecombe (1999), which applied the PDP to the category production task to investigate effects of attention on conscious and automatic memory. She found that a manipulation of attention at study affected both *C* and *A* memory processes in the category production task but affected conscious memory only in the word stem completion task. These results indicate a conceptual effect on automatic memory. Another recent study by Bergerbest and Goshen-Gottstein (2002) manipulated levels of processing in the PDP with a conceptual word association task. They found that levels of processing affected *C* and *A* estimates, providing additional support for conceptual influences on automatic memory.

The Present Study

In the present study, the PDP was applied to the category production task to further investigate conceptual processing effects on automatic forms of memory. A levels-of-processing study manipulation was used to examine influences of encoding processing differences on conscious and automatic memory for category production. On the basis of the results of previous studies suggesting that this task is influenced by conceptual processing (e.g., McBride & Doshier, 2002; Toth et al., 1994; Weldon & Coyote, 1996), it was expected that the semantic study condition would result in higher *C* estimates than would the graphemic study task. A similar finding for *A* estimates would confirm that the levels-of-processing effect on implicit memory shown in past studies (Hamann, 1990; Lee, 2000; Masson & MacLeod, 1992; Srinivas & Roediger, 1990; Weldon & Coyote, 1996) was not merely a result of explicit contamination (see also Bodner, Masson, & Cald-

well, 2000) and would support Toth and Reingold's (1996) suggestion that conceptual processing influences automatic memory.

Process tree models. One limitation of the PDP concerns the retrieval strategy used by the study subjects. It has been suggested that the PDP equations may provide inaccurate estimates of conscious and automatic memory when subjects engage in a generate-recognize retrieval strategy, rather than relying on direct retrieval (Bodner et al., 2000; Jacoby, 1998). However, multinomial process tree models (Batchelder & Riefer, 1999) can be developed that represent the independence relation specified by the original PDP equations (direct retrieval models) or the generate-recognize model of memory retrieval (generate-source models). Direct retrieval models assume that direct, intentional retrieval of items occurs in the inclusion and exclusion tasks in the PDP, whereas generate-source models assume that a generate-recognize strategy (i.e., responses are generated and then evaluated as studied or unstudied) is employed. Therefore, the use of multinomial models in conjunction with the PDP tasks (inclusion and exclusion) to estimate *C* and *A* processes may help researchers to make accurate estimations of the memory processes, regardless of the retrieval strategy used by the subjects.

Recent studies have begun to use multinomial models to estimate *C* and *A* memory from PDP task performance (Bodner et al., 2000; Buchner, Erdfelder, & Vaterrodt-Plünnecke, 1995; Jacoby, 1998; McBride & Doshier, 1999, 2002; McBride, Doshier, & Gage, 2001; Schmitter-Edgecombe, 1999). For example, Jacoby (1998) fit a direct retrieval model and a generate-source model to data from a stem completion task in the PDP. His study showed that retrieval strategy instructions can influence the fit of different models. When direct retrieval instructions were given in the PDP, a direct retrieval model fit the data well, but this model did not fit data from the tasks when generate-recognize instructions were given. The reverse was true for a generate-source model fit to these data. Jacoby (1998) also suggested that when baseline rates are unequal in the inclusion and the exclusion tasks, the direct retrieval model may be inappropriate, because the independence assumption of the PDP equations may be violated. Furthermore, Bodner et al. (2000) showed that the direct retrieval model may be inappropriate even if direct retrieval instructions are used and baseline rates are found to be equivalent in the inclusion and the exclusion tasks. These results suggest that both direct retrieval and generate-source models should be considered when estimating *C* and *A* memory from the PDP tasks.

Direct retrieval instructions were given in the present study but, on the basis of the argument just presented, direct retrieval and generate-source models were both fit to data from the category production task. The direct retrieval model was derived from the original PDP equations, assumed independence between *C* and *A*, and was found to fit stem completion data from the PDP when a direct retrieval strategy was used by the subjects (Bodner

et al., 2000; Jacoby, 1998). Schmitter-Edgecombe (1999) also found this model to fit data from a category production task. The process trees follow a direct retrieval strategy that assumes that subjects attempt direct, conscious retrieval of the target. Automatic memory (A) for the item may also occur, regardless of the success of conscious retrieval (C or $1 - C$). The conscious process is one in which subjects are aware that they have retrieved a target (studied) item, whereas the automatic process in this model is one in which the subject is unaware of retrieving the target item. In the absence of C or A memory, a studied item response is possible through guessing (G). It is assumed that the guessing process is used only when there is no memory of the target item ($1 - C$ and $1 - A$). A parameter that estimated the likelihood of responding with an alternative (i.e., nontarget) item was added to this model. The alternate word generation (W) process may occur in some cases, depending on the task instructions and the success of the C and A processes. This parameter was added to the original Jacoby (1998) models to estimate the probability of generating a nontarget response in the inclusion and exclusion tasks, as separate from the probability of a no-answer (xxx) response. Therefore, without the W parameter, no distinction can be made in the models between nontarget (alternate) word responses and no-answer (xxx) responses. Separate W parameters are estimated for the inclusion and the exclusion tasks (W_I and W_E , respectively), since the probability of generating a nontarget response, as opposed to a no-answer response, may differ between the two tasks. McBride and Doshier (1999, 2002) and McBride et al. (2001) fit models that included the W parameter to stem completion task data from the PDP. In cases in which memory for the target is available (either C or A), the memory processes and instructions in the inclusion and exclusion tasks determine whether the target will be given as a response [e.g., in the ($1 - C$) A branches of the trees, automatic memory is sufficient for responding with the target in each case, because responding with any item that fits the cue is allowed in the inclusion task, and in the exclusion task any response without conscious awareness of its study episode is allowed]. The product of the branch probabilities within the model tree indicates the probability of producing the response at the end of the branch. An illustration of this model is given in Figure 1. Separate trees are shown for inclusion and exclusion tasks, and the model estimates different C and A parameters for each of the two study task conditions (semantic and graphemic). Both models are classified as high-threshold models (i.e., they both assume that $C = 0$ and $A = 0$ for unstudied items).

Generate–source models have also been used in previous studies (Bodner et al., 2000; Jacoby, 1998; McBride & Doshier, 2002) in fits to data from the PDP. The generate–source model tree structure is similar to the structure of the direct retrieval model, but the generate–source model is based on a generate–recognize strategy (i.e., a response is generated through an automatic process and then evaluated with a conscious recognition process). Subjects may

generate a target item through the automatic memory process (A) in this model. If they fail to generate a target item ($1 - A$), a target may still be produced through an automatic guessing generation process (G) that does not rely on memory of the target. Once an item has been generated (a target, through either the A process or the G process), the subjects then subject the item to a conscious source match with items they studied earlier (C). If the subjects are unable to generate the target item (through A or G), they respond either with a nontarget (alternate) word that fits the cue through the W process or with no answer (xxx) with a probability of $1 - W$. The generate–source model does not assume independence between C and A , since the C process is not engaged in every A and $1 - A$ branch. The generate–source model fit in the present study is displayed in Figure 2.

The direct retrieval and generate–source models just described were fit in the present study to response frequency data from the category production task to estimate C and A memory processes. Memory parameters for the semantic (C_S and A_S for conscious and automatic memory) and graphemic (C_G and A_G for conscious and automatic memory) study conditions were compared for each model to evaluate levels-of-processing effects on each memory process, using nested model fits that assumed equivalent memory parameters for the two study conditions.

METHOD

Subjects

Thirty-nine undergraduate students at Illinois State University were subjects in the experiment. All the students were native English speakers and received extra credit for their participation. Data from 1 subject were removed due to a failure to follow instructions, leaving 38 sets of data for analysis.

Materials and Design

The categories and exemplar items used in this study were modeled from stimuli developed in a previous PDP study of the category production task (McBride & Doshier, 2002). Sixteen categories (e.g., furniture, colors) were chosen from the Battig and Montague (1969) category norms, with six exemplars per category (e.g., couch, blue), for a total of 96 target items. Within each category, each exemplar began with a unique letter. For each category, there was at least one nontarget (i.e., alternate) item that began with the same letter as the target. Words were randomly assigned to three lists of 32 items for counterbalancing of the study tasks (semantic, graphemic, and unstudied). Each study task list contained two randomly chosen exemplars from each category. From these lists, 1 item per category was randomly selected for the inclusion task, and the other item was presented in the exclusion task. Therefore, for each subject, 16 items were assigned to each study task by test task condition. Study task and test task factors were manipulated within subjects.

Procedure

The subjects began by completing the study portion of the experiment. Sixty-four words were presented one at a time in the center of the computer screen. A symbol (! or *) preceded each word to indicate the study task. The subjects were instructed to rate the pleasantness of the word on a 1 to 7 scale if the ! appeared before the word. If the * appeared before the word, they were to count the number of vowels in the word. The subjects pressed a number on the number pad of the keyboard for each item, and then the next word

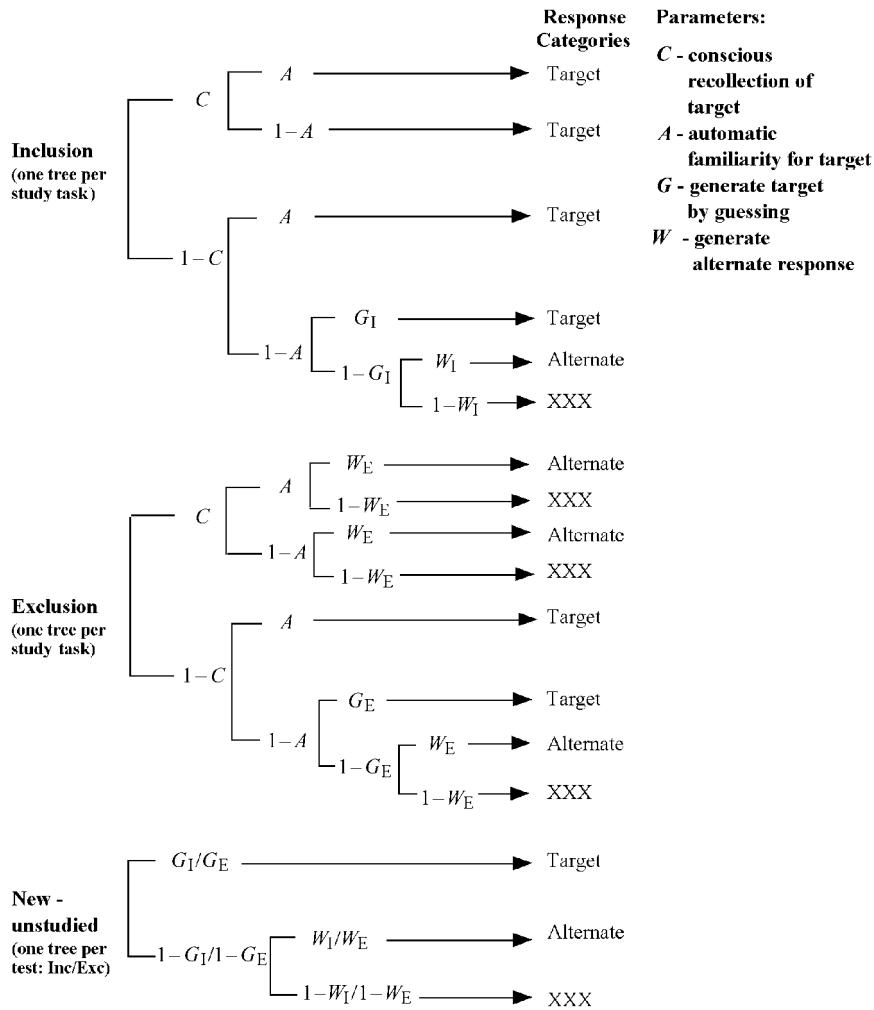

Figure 1. Direct retrieval model derived from Jacoby (1998). This model follows a direct retrieval strategy.

and study symbol were shown. Symbols were displayed for 2 sec, and the words remained on the screen until a response was made by the subject.¹ Each subject received a different random order of the study items. Example items were presented in the instructions, to illustrate the tasks.

During the test phase, the first letter of each of the 96 target items was presented with its category name (e.g., furniture-c). The message “Old” or “New” was also presented to indicate the inclusion and the exclusion task instructions, respectively. A cue card on the computer also provided a reminder of the inclusion/exclusion instructions associated with each message. For the inclusion trials, the subjects were instructed to attempt to recall an item they had studied that started with the letter given and belonged to the category presented. If they could not remember a studied item that fit the cue, they were to respond with any item that fit the cue. For exclusion trials, the subjects were instructed to use the cue to attempt to remember a studied item but then to generate a new (unstudied) item that fit the cue as their response. In other words, on exclusion trials, they were to respond with an exemplar of the category that they had not studied in the first portion of the experiment. These instructions were designed to encourage a direct retrieval strategy (see Jacoby, 1998). Examples of each type of task were presented to help the sub-

jects understand the instructions. All instructions were read aloud to the subjects as they followed along on the screen.

Each test item was presented for 4 sec or until the subject pressed the space key to begin typing their response. The subjects were asked to type the entire word for their response at a prompt that appeared at the top of the screen. For both tasks (inclusion and exclusion), the subjects were asked to type “xxx” if they could not come up with a response that fit the cue and the instructions. The next test item was not presented until the subject had typed a response and hit the return key. Test trials were presented in a different random order for each subject.

Response Coding

Studied items and minor misspellings of studied items were coded as targets. All other word responses were coded as alternate items.

RESULTS

Response category frequencies were determined across subjects for each study task by test task condition. These data are presented in Table 1. Each row of Table 1 pre-

sents response category frequencies for 608 total trials (38 subjects \times 16 trials per condition).

Jacoby Equation Estimates

Jacoby's (1991) PDP equations were used to calculate parameter estimates for conscious and automatic memory processes for each of the three study conditions (semantic, graphemic, and unstudied). These estimates are included in Table 2. A 2 (memory process) \times 3 (study condition) repeated measures analysis of variance indicated significant main effects of memory process [$F(1,37) = 36.70, p < .001$] and study condition [$F(2,74) = 28.08, p < .001$], as well as a significant interaction [$F(2,74) = 43.66, p < .001$]. Bonferroni tests further indicated that the conscious memory estimate for semantic study ($M =$

.33) was higher than the conscious estimate for graphemic study [$M = .11; t(37) = 6.80, p < .001$], whereas the automatic memory estimates showed the opposite pattern [i.e., semantic lower than graphemic, with means of .23 and .31, respectively; $t(37) = -4.29, p < .001$]. The automatic estimate for the semantic study condition (A_S) was also found to be lower than the average target baseline rate [$M = .32; t(37) = -3.967, p < .001$], indicating that the subjects may have been employing a generate-recognize strategy to complete the tasks.

Multinomial Model Estimates

The direct retrieval and generate-source models displayed in Figures 1 and 2 were fit to the response frequency data presented in Table 1, using the AppleTree pro-

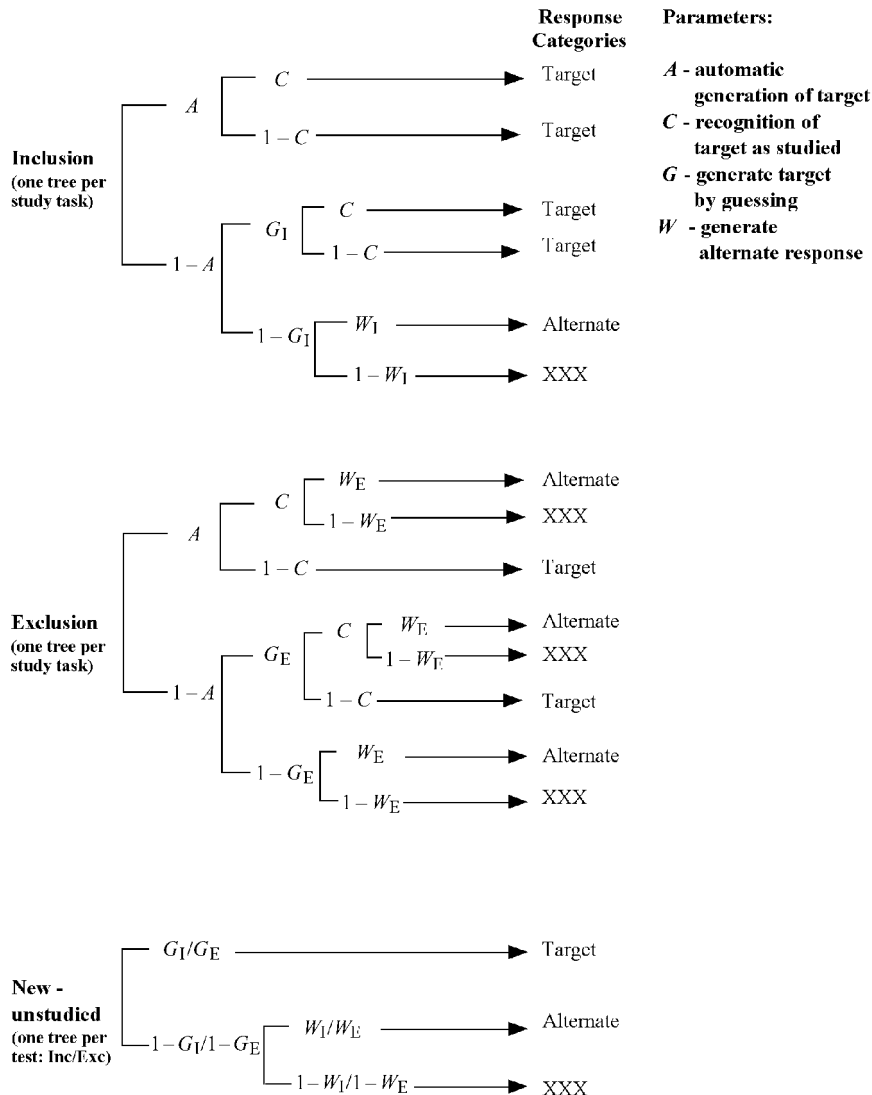

Figure 2. Generate-source model derived from Jacoby (1998). This model follows a generate-recognize strategy.

Table 1
Response Frequency (*F*) Data for Each Study Task by Test Task Condition,
With Proportions (*P*s)

Condition	Target		Alternate		No Response (xxx)	
	<i>F</i>	<i>P</i>	<i>F</i>	<i>P</i>	<i>F</i>	<i>P</i>
Inclusion						
Semantic	300	.493	124	.204	184	.303
Graphemic	237	.390	135	.222	236	.388
Unstudied	180	.296	150	.247	278	.457
Exclusion						
Semantic	98	.161	286	.470	224	.368
Graphemic	171	.281	255	.419	182	.299
Unstudied	204	.336	250	.411	154	.253

gram by Rothkegel (1999) to estimate *C* and *A* memory processes for semantic and graphemic study conditions. In examining model fit, we used the G^2 statistic (Hu & Batchelder, 1994), which is distributed similarly to χ^2 . Parameter estimates are presented in Table 2 for the direct retrieval and the generate–source models. Two nested models were developed from each full model: one that assumed $C_S = C_G$ and one that assumed $A_S = A_G$. These models were fit to the data and were compared with the full model for statistical comparison of the *C* and *A* estimates for the study task conditions. A $G^2(1)$ difference was calculated for each nested model from the full model to determine whether the nested model fit was a significantly worse fit than the full model. An alpha of .005 was used in accordance with previous studies involving multinomial model fits (Bodner et al., 2000; Erdfelder & Bredenkamp, 1998; Jacoby, 1998; McBride & Doshier, 2002). Power was above .99 in all fits, and effect sizes ranged from .04 to .12.

The direct retrieval model did not fit the data well [$G^2(4) = 17.40, p = .002$]. This result may indicate use of a generate–recognize retrieval strategy. Because of the poor fit of this model, no nested models tests are reported.

Further support of the use of a generate–recognize strategy is provided by the good fit of the generate–source model to the data [$G^2(4) = 5.30, p = .258$]. Conscious and automatic estimates for this model followed predictions of a levels-of-processing effect on both memory processes. The nested model fits indicate that the *C* estimates for semantic and graphemic study were significantly different [$G^2(1) = 38.18, p < .005$]. The same results were found for the *A* estimates [$G^2(1) = 13.26, p < .005$], indicating a conceptual influence on automatic memory.

From the model fits described above, it appears that the generate–source model provides the better description of the data from the category production task in the present study. This may be due to a reliance on a generate–recognize strategy by the subjects, despite use of direct retrieval instructions in this experiment. Jacoby (1998) has suggested that evidence of baseline differences between the PDP tasks may indicate use of a generate–recognize retrieval strategy. A comparison of the baseline (unstudied) rates in the inclusion and the exclusion tasks provided no evidence of a difference between the tasks [$t(37) = 1.24, p > .05$]. However, Bodner et al. (2000) have also suggested a

comparison of the automatic estimate with the average baseline target completion rate as a further test of the use of a generate–recognize strategy. As was noted above for the Jacoby equation estimates, the automatic estimate for the semantic study condition was found to be lower than the average target baseline rate. In addition, *G* estimates from the generate–source model differed for the two tasks ($G_I = .296$ for inclusion and $G_E = .336$ for exclusion), indicating a difference in the likelihood of generating the target through guessing. This result does suggest a strategic difference between the inclusion and the exclusion tasks, which can be interpreted as evidence that independence between *C* and *A* has been violated for these data. Therefore, it is likely that the subjects used a generate–recognize strategy, rather than a direct retrieval strategy, to complete the tasks, making the generate–recognize model a better description of the data in the present study.

DISCUSSION

The results of the present study provide support for a conceptual influence on both conscious and automatic memory in conceptual tasks. The conscious estimates for the semantic study condition were higher than those for the graphemic study condition for both models. The automatic estimate was also higher for the semantic condition than for the graphemic condition for the generate–source

Table 2
Parameter Estimates from Jacoby (1991) Equations and Direct Retrieval and Generate–Source Multinomial Model Fits

Model	Conscious		Automatic	
	<i>M</i>	<i>SD</i>	<i>M</i>	<i>SD</i>
Jacoby (1991) equations				
Semantic	.332	.180	.228	.122
Graphemic	.109	.193	.309	.104
Unstudied	-.004	.176	.322	.010
Direct retrieval model*				
Semantic	.331	.031	.001	.033
Graphemic	.124	.034	.030	.029
Generate–source model†				
Semantic	.691	.033	.280	.034
Graphemic	.337	.063	.133	.036

* $G^2(4) = 17.40, p = .002; G_I = .282, G_E = .301, W_I = .369, W_E = .585$.
 † $G^2(4) = 5.30, p = .258; G_I = .296, G_E = .336, W_I = .369, W_E = .585$.

model. These results support the levels-of-processing effects shown for explicit and implicit task performance on conceptual tests (Hamann, 1990; Lee, 2000; Srinivas & Roediger, 1990; Weldon & Coyote, 1996), while controlling for the confound of explicit contamination in the implicit tasks. The present findings provide evidence of a conceptual study manipulation on automatic memory estimates.

Conceptual Processing and Automatic Memory

In several previous studies (see Toth & Reingold, 1996, for a review), conceptual effects on automatic forms of memory have been examined. Overall, conceptual manipulations appear to influence conscious memory in most explicit tests but also influence automatic memory in implicit conceptual tests. For example, Roediger et al. (1992) found levels-of-processing effects on explicit word stem and fragment completion tasks, but no effect on implicit forms of these perceptual tasks. McBride and Doshier (1999) and McBride et al. (2001) further supported these results, using multinomial models to estimate *C* and *A* processes for word stem and fragment completion tasks, respectively. Conceptual implicit tasks, however, have been shown to be influenced by conceptual encoding manipulations. Weldon and Coyote (1996) found levels-of-processing effects in explicit and implicit category production and word association tasks. Furthermore, Mulligan (1997) found that dividing attention affected explicit and implicit task performance in category production, and Schmitter-Edgecombe (1999) confirmed these findings, using the PDP and a direct retrieval multinomial model to estimate *C* and *A* memory processes.

Using the PDP and multinomial models to estimate *C* and *A* memory processes, the present study contributes further evidence of conceptual effects on automatic memory by supporting Weldon and Coyote's (1996) finding of levels-of-processing effects in category production. The present results suggest that conceptual effects on automatic memory are not merely due to an artifact of explicit contamination. These results are also consistent with a transfer-appropriate processing explanation of memory task results (Roediger, 1990). Conceptual processing employed in the semantic study task during encoding is reinstated at retrieval in the category production task, resulting in better memory for semantic study items. Furthermore, semantic encoding elevates both conscious and automatic memory in this task, indicating that processing type is the predictive factor for memory results, not the memory process (conscious or automatic) employed for retrieval.

The Models

In addition to the studies by McBride and Doshier (2002) and Schmitter-Edgecombe (1999), the present study further extends the use of multinomial models to the case of category production tasks for estimating conscious and automatic memory processes. It has been shown in past studies that each model (direct retrieval and generate-source) is appropriate for different retrieval strategies. Jacoby (1998) manipulated retrieval instructions and found that each model fit the data only when the corresponding

retrieval instruction was given. Bodner et al. (2000) further concluded that instructions are not sufficient for a good model fit; the actual strategy used by the subjects is the primary factor, and their results indicated that the instructions given did not always dictate the strategy used by the subjects. Therefore, it is important to consider both direct retrieval and generate-source models when estimating processes from data produced in the PDP, such as the models considered in the present study.

Although the direct retrieval model has been found to be appropriate under certain conditions (Bodner et al., 2000; Jacoby, 1998), it provided a poor fit to data in the present study. This result is likely a direct result of a failure to induce a direct retrieval strategy in the present study, despite use of direct retrieval instructions. The data from the category production task were better described by a generate-source model, which likely indicates use of a generate-recognize strategy by the subjects. Although no baseline differences were found between inclusion and exclusion tasks in the present study, the direct retrieval model automatic memory estimate for the semantic study condition was found to be lower than the average baseline target completion rate. Furthermore, when the assumptions of the direct retrieval model (e.g., assumption of independence between *C* and *A* memory processes) have been violated, it has been suggested that the model underestimates *A* processes (Bodner et al., 2000; Curran & Hintzman, 1995; Russo, Cullis, & Parkin, 1998), which could account for the low *A* estimates found in the present study. In fact, Bodner et al. argued that the exclusion criterion applied by subjects may be the cause of the underestimation of *A* estimates in conceptual conditions for the direct retrieval model. The lower target response rate for the semantic condition ($M = 2.58$) than for the graphemic condition ($M = 4.50$) in the exclusion task for the present study [$t(37) = -6.071, p < .001$] supports their argument and provides strong evidence that a generate-recognize strategy was employed. These issues should be considered in future studies when processes are estimated using the PDP.

In summary, the present study was designed to examine conceptual effects on automatic memory for a conceptual task, using the PDP and multinomial model fits to estimate memory processes. Previous studies (e.g., Hamann, 1990; Lee, 2000; Srinivas & Roediger, 1990; Weldon & Coyote, 1996) have found levels-of-processing effects on conceptual implicit task performance. The memory estimates from the generate-source model support conclusions from past studies in which conceptual influences on implicit/automatic memory have been examined.

REFERENCES

- BATCHELDER, W. H., & RIEFER, D. M. (1999). Theoretical and empirical review of multinomial process tree modeling. *Psychonomic Bulletin & Review*, *6*, 57-86.
- BATTIG, W. F., & MONTAGUE, W. E. (1969). Category norms for verbal items in 56 categories: A replication and extension of the Connecticut category norms. *Journal of Experimental Psychology Monographs*, *80*(3, Pt. 2).
- BERGERBEST, D., & GOSHEN-GOTTSTEIN, Y. (2002). The origins of levels-of-processing effects in a conceptual test: Evidence for auto-

- matic influences of memory from the process-dissociation procedure. *Memory & Cognition*, **30**, 1252-1262.
- BODNER, G. E., MASSON, M. E. J., & CALDWELL, J. I. (2000). Evidence for a generate-recognize model of episodic influences on word-stem completion. *Journal of Experimental Psychology: Learning, Memory, & Cognition*, **26**, 267-293.
- BROWN, A. S., & MITCHELL, D. B. (1994). A reevaluation of semantic versus nonsemantic processing in implicit memory. *Memory & Cognition*, **22**, 533-541.
- BUCHNER, A., ERDFELDER, E., & VATERRODT-PLÜNNECKE, B. (1995). Toward unbiased measurement of conscious and unconscious memory processes within the process dissociation framework. *Journal of Experimental Psychology: General*, **124**, 137-160.
- CHALLIS, B. H., & BRODBECK, D. R. (1992). Level of processing affects priming in word-fragment completion. *Journal of Experimental Psychology: Learning, Memory, & Cognition*, **18**, 595-607.
- CURRAN, T., & HINTZMAN, D. L. (1995). Violations of the independence assumption in process dissociation. *Journal of Experimental Psychology: Learning, Memory, & Cognition*, **21**, 531-547.
- ERDFELDER, E., & BREDEKAMP, J. (1998). Recognition of script-typical versus script-atypical information: Effects of cognitive elaboration. *Memory & Cognition*, **26**, 922-938.
- HAMANN, S. B. (1990). Level-of-processing effects in conceptually driven implicit tasks. *Journal of Experimental Psychology: Learning, Memory, & Cognition*, **16**, 970-977.
- HORTON, K. D., WILSON, D. E., & EVANS, M. (2001). Measuring automatic retrieval. *Journal of Experimental Psychology: Learning, Memory, & Cognition*, **27**, 958-966.
- HU, X., & BATCHELDER, W. H. (1994). The statistical analysis of general processing tree models with the EM algorithm. *Psychometrika*, **59**, 21-47.
- JACOBY, L. L. (1991). A process dissociation framework: Separating automatic from intentional uses of memory. *Journal of Memory & Language*, **30**, 513-541.
- JACOBY, L. L. (1998). Invariance in automatic influences of memory: Toward a user's guide for the process-dissociation procedure. *Journal of Experimental Psychology: Learning, Memory, & Cognition*, **24**, 3-26.
- JACOBY, L. L., TOTH, J. P., & YONELINAS, A. P. (1993). Separating conscious and unconscious influences of memory: Measuring recollection. *Journal of Experimental Psychology: General*, **122**, 139-154.
- LEE, Y. (2000). The role of conscious memory in the category-production task. *European Journal of Cognitive Psychology*, **12**, 453-471.
- MASSON, M. E. J., & MACLEOD, C. M. (1992). Reenacting the route to interpretation: Enhanced perceptual identification without prior perception. *Journal of Experimental Psychology: General*, **121**, 145-176.
- MCBRIDE, D. M., & DOSHER, B. A. (1999). Forgetting rates are comparable in conscious and automatic memory: A process-dissociation study. *Journal of Experimental Psychology: Learning, Memory, & Cognition*, **25**, 583-607.
- MCBRIDE, D. M., & DOSHER, B. A. (2002). A comparison of conscious and automatic memory processes for picture and word stimuli: A process dissociation analysis. *Consciousness & Cognition*, **11**, 423-460.
- MCBRIDE, D. M., DOSHER, B. A., & GAGE, N. M. (2001). A comparison of forgetting for conscious and automatic memory processes in word fragment completion tasks. *Journal of Memory & Language*, **45**, 585-615.
- MULLIGAN, N. W. (1997). Attention and implicit memory tests: The effects of varying attentional load on conceptual priming. *Memory & Cognition*, **25**, 11-17.
- MULLIGAN, N. W. (1998). The role of attention during encoding in implicit and explicit memory. *Journal of Experimental Psychology: Learning, Memory, & Cognition*, **24**, 27-47.
- ROEDIGER, H. L., III (1990). Implicit memory: Retention without remembering. *American Psychologist*, **45**, 1043-1056.
- ROEDIGER, H. L., III, & McDERMOTT, K. B. (1993). Implicit memory in normal human subjects. In F. Boller & J. Grafman (Eds.), *Handbook of neuropsychology* (Vol. 8, pp. 63-131). Amsterdam: Elsevier.
- ROEDIGER, H. L., III, WELDON, M. S., STADLER, M. A., & RIEGLER, G. H. (1992). Direct comparison of two implicit memory tests: Word fragment and word stem completion. *Journal of Experimental Psychology: Learning, Memory, & Cognition*, **18**, 1251-1269.
- ROTHKEGEL, R. (1999). AppleTree: A multinomial processing tree modeling program for Macintosh computers. *Behavior Research Methods, Instruments, & Computers*, **31**, 696-700.
- RUSO, R., CULLIS, A. M., & PARKIN, A. J. (1998). Consequences of violating the assumption of independence in the process dissociation procedure: A word fragment completion study. *Memory & Cognition*, **26**, 617-632.
- SCHMITTER-EDGECOMBE, M. (1999). Effects of divided attention on perceptual and conceptual memory tests: An analysis using a process-dissociation approach. *Memory & Cognition*, **27**, 512-525.
- SRINIVAS, K., & ROEDIGER, H. L., III (1990). Classifying implicit memory tests: Category association and anagram solution. *Journal of Memory & Language*, **29**, 389-412.
- TOTH, J. P., & REINGOLD, E. M. (1996). Beyond perception: Conceptual contributions to unconscious influences of memory. In G. Underwood (Ed.), *Implicit cognition* (pp. 41-84). New York: Oxford University Press.
- TOTH, J. P., REINGOLD, E. M., & JACOBY, L. L. (1994). Toward a redefinition of implicit memory: Process dissociations following elaborative processing and self generation. *Journal of Experimental Psychology: Learning, Memory, & Cognition*, **20**, 290-303.
- WELDON, M. S., & COYOTE, K. C. (1996). Failure to find the picture superiority effect in implicit conceptual memory tests. *Journal of Experimental Psychology: Learning, Memory, & Cognition*, **22**, 670-686.

NOTE

1. A separate group of subjects ($N = 33$) completed the experiment with study presentation set at 3 sec for both study tasks. The results for this group did not differ from those reported here.

(Manuscript received July 4, 2002;
revision accepted for publication December 5, 2002.)